



actual size

Oscillator · JO53 · 3.0 V

SMD Oscillator with Stop Function · 5.0 x 3.2 mm

- high temperature version available
- reflow soldering temperature: 260 °C max.
- ceramic/metal package



General Data

type	JO53 3.0 V	
frequency range	0.50 ~ 125.0 MHz (15 pF max.)	
	0.50 ~ 50.0 MHz (30 pF max.)	
	2.00 ~ 50.0 MHz (15 pF max. for T2 & T3*)	
frequency stability over all**	± 20 ppm ~ ± 100 ppm (table 1)	
current consumption	see table 2	
supply voltage V_{DC}	3.0 V ± 5%	
temperature	operating	-10 °C ~ +70 °C
		-40 °C ~ +85 °C
		-40 °C ~ +105 °C
		-40 °C ~ +125 °C ask if available
storage	-55 °C ~ +125 °C	
output	rise & fall time	see table 3
	load max.	15 pF / 30 pF (≤ +85 °C and ≤ 50.0 MHz)
	current max.	5 mA / 4 mA (T2 & T3*)
	low level max.	0.1 x V _{DC} / 0.4 V (T2 & T3*)
	high level min.	0.9 x V _{DC} / V _{DC} - 0.4 V (T2 & T3*)
output enable time max.	10 ms	
output disable time max.	150 ns / 200 ns (T2 & T3*)	
start-up time max.	10 ms	
standby function	stop	
standby current max.	10 µA / 20 µA (T2 & T3*)	
phase jitter 12 kHz ~ 20.0 MHz	< 1.0 ps RMS	
symmetry at 0.5 x V_{DC}	45% ~ 55% (40% ~ 60% max.)	

* ask if available

Table 1: Frequency Stability Code

stability code		A	B	G	C	D
		± 100 ppm	± 50 ppm	± 30 ppm	± 25 ppm	± 20 ppm
-10 °C ~ +70 °C	STD.		●	○	○	Δ
-40 °C ~ +85 °C	T1	●	●	○	○	
-40 °C ~ +105 °C	T2	○	○			
-40 °C ~ +125 °C	T3*	■				

● standard ○ available ■ ask if available Δ excludes aging

** includes stability at 25 °C, operating temp. range, supply voltage change, shock and vibration, aging 1st year.

Table 2: Current Consumption max.

Current at 15 pF load		Current at 30 pF load	
0.5 ~ 29.9 MHz	10 mA	0.5 ~ 29.9 MHz	10 mA
30.0 ~ 49.9 MHz	20 mA	30.0 ~ 50.0 MHz	25 mA
50.0 ~ 79.9 MHz	30 mA		
80.0 ~ 125.0 MHz	40 mA		

Table 3: Rise & Fall Time max.

at 15 pF	at 30 pF
6 ns: 0.50 ~ 1.79 MHz	7 ns: 0.50 ~ 50.00 MHz
5 ns: 1.80 ~ 49.99 MHz	
4 ns: 50.00 ~ 125.00 MHz	

note: rise time: 0.1 V_{DC} ~ 0.9 V_{DC} / fall time: 0.9 V_{DC} ~ 0.1 V_{DC}
specific data on request

Dimensions

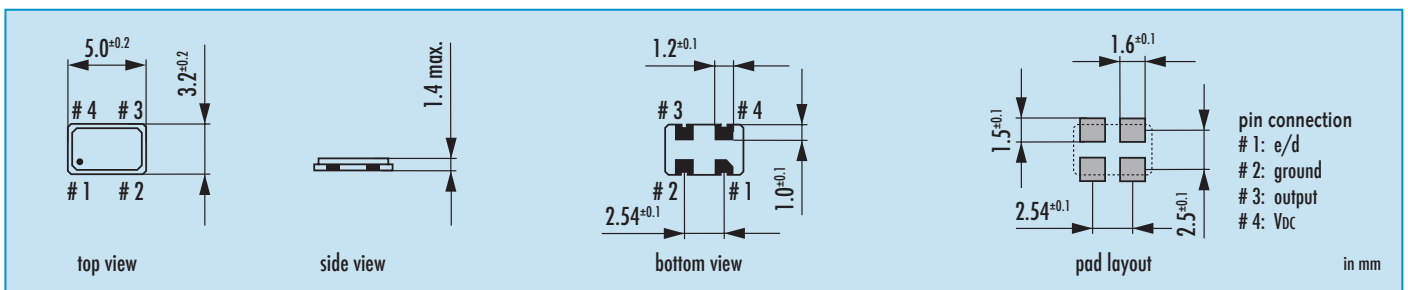

Order Information

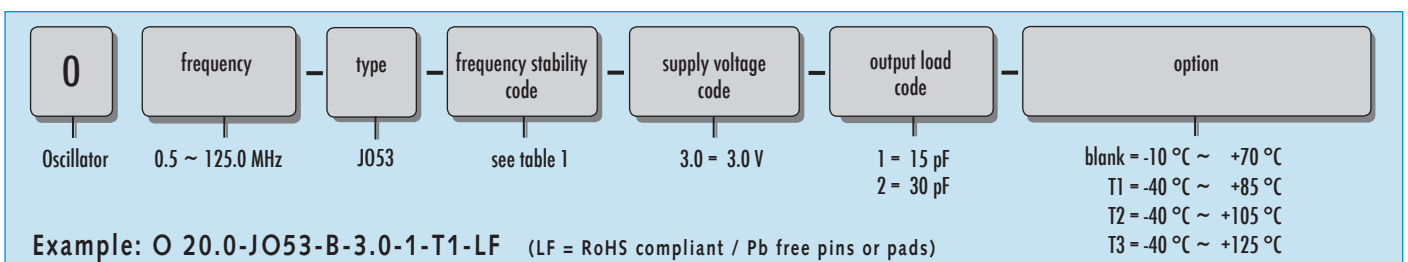

Oscillator · JO53 · 3.0 V · Stop Function

Taping Specification

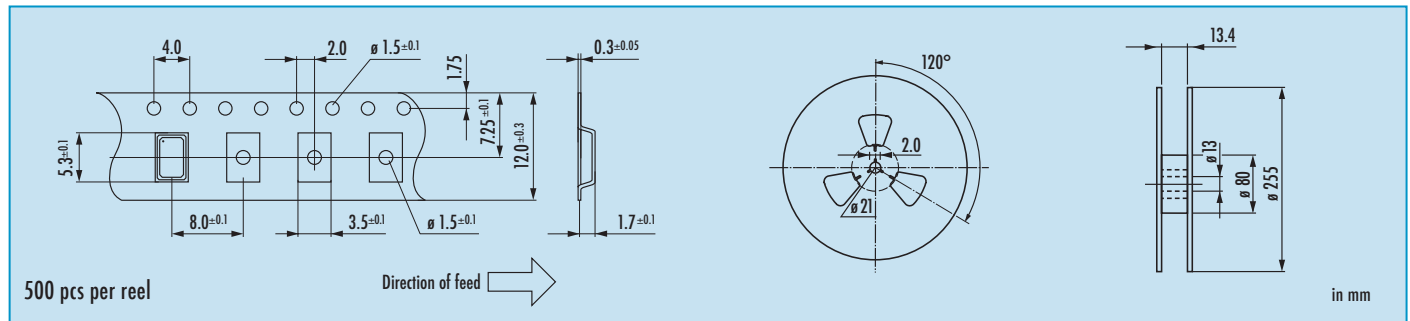

Enable / Disable Function

pin #1 (e/d control)	pin #3 (output)
open	active
high "1" ($V_{IH} \geq 0.8 V_{DC}$)	active
low "0" ($V_{IL} \leq 0.2 V_{DC}$)	high impedance
stop function:	
<ul style="list-style-type: none"> oscillator stops output high impedance 	

Marking

frequency
type / date code

date code:

A ~ M: Jan. - Dec.

2: 2012 5: 2015

3: 2013 6: 2016

4: 2014 7: 2017

Jan.	Febr.	Mar.	Apr.	May	June
A	B	C	D	E	F
July	Aug.	Sept.	Oct.	Nov.	Dec.
G	H	J	K	L	M

Reflow Soldering Profile

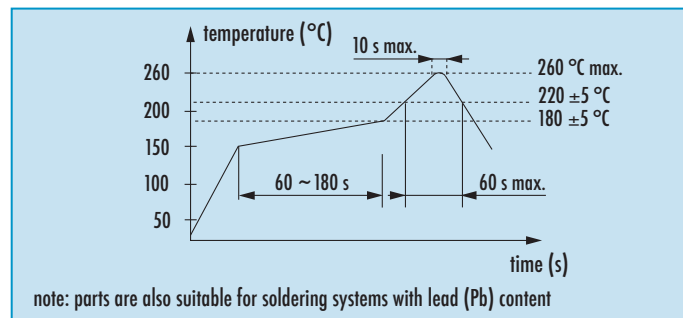

Packing Note

- standard packing units are 500 pieces per reel
- non-multiple packing units are only supplied taped / bulk